

Art of Smooth Performance

VTURN S20/S26/S36

Strong
and
Steady
Turning
Center

- **Servo turret** (S20(CM), S26(CM), S36CM)
- **One-piece slant bed**
- **Box slideways**
- **High thrust force**
- **C-axis available**
- **Rotary operation panel**



Smooth & Steady Performance

Vturn-S20 Turning center

- One piece 30° slant bed
- Large swing diameter 600 mm
- 8" Power chuck / 4200 rpm
- Z-axis travel 400 / 600 mm (S20/40, S20/60)
- Programmable tailstock
- Machine width 2300 mm only (S20/40) with rear disposal chip conveyor
- High rapid feed 20/24 m/min (X/Z)
- C-axis available



Vturn-S20/40



Spindle 12 kW (S3-15%)

- Spindle output 246 Nm (S3-15%)
- Low base speed 349 rpm only
- NN type (roller type) bearings
- Shortened belt length
- Victor Taichung's own spindle

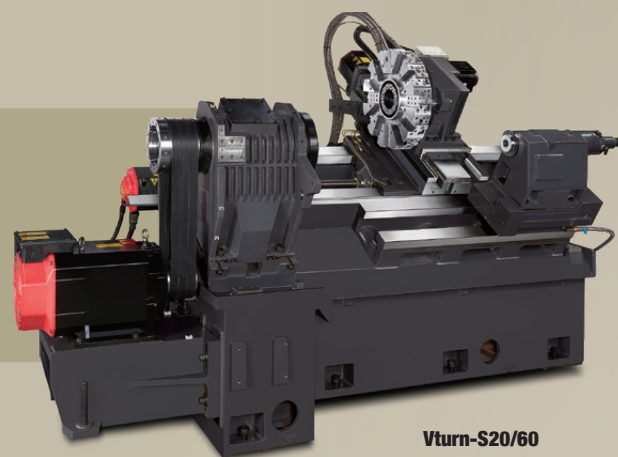
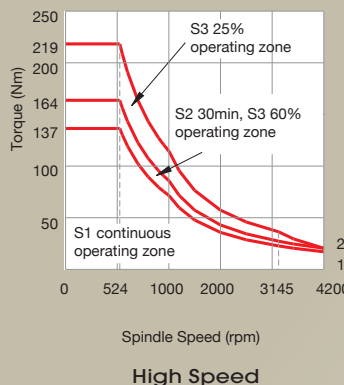
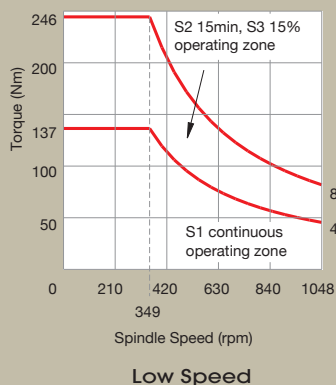
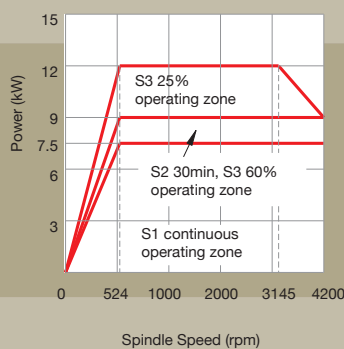
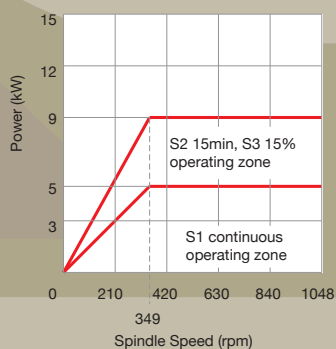

Vturn-S20/60

Boxways 55/70 mm (X/Z)

- High rapid feeds 20/24 m/min
- Smooth operation guaranteed
- Victor Taichung's own casting

Fanuc motor αiP15

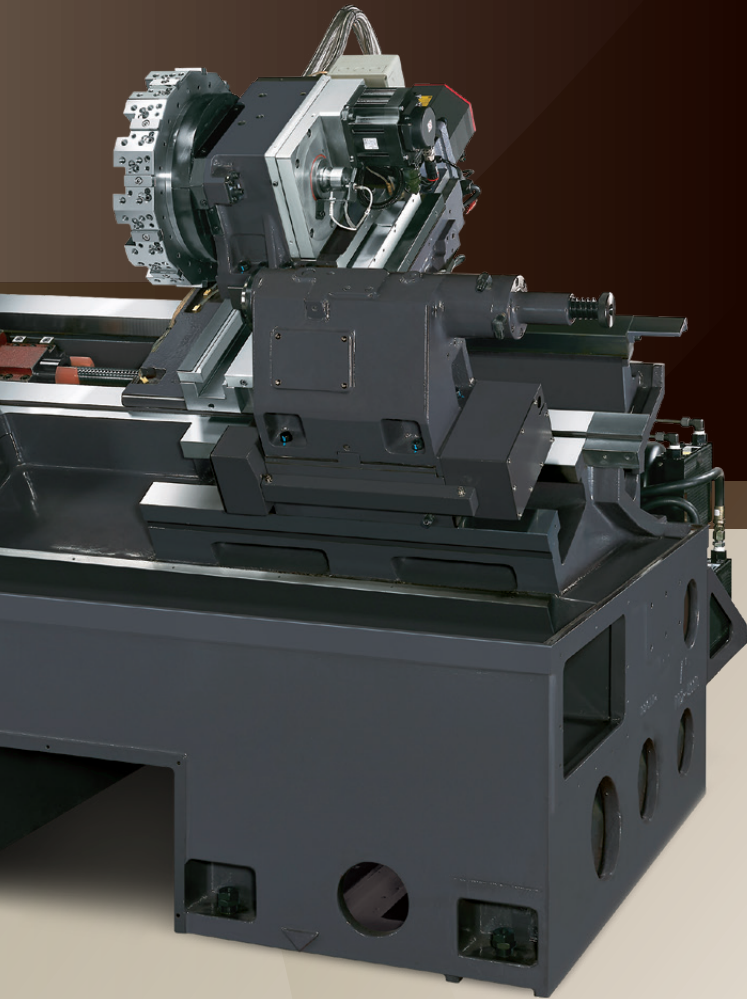

Vturn-S20/40

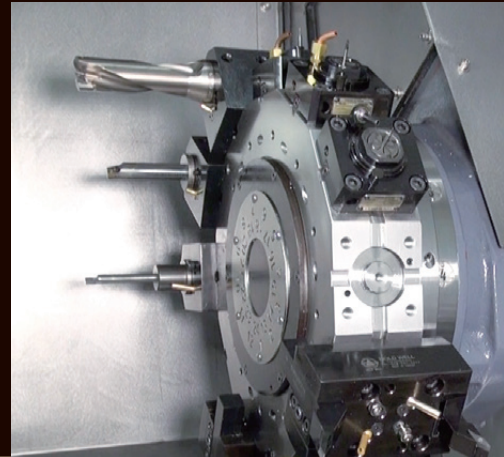

Victor's Own Turret 0.8 sec. (adjacent tools)

- Turret indexing time 0.8 sec (adj.), 1.0 (opposite)
- High thrust (Z-axis) 852 kgf (8.36 kN)
- Opt. milling turret BMT-55 (3 piece coupling, servo)
- 12 station live tools
- Milling power 2.2 kW / 4000 rpm (opt. 6000 rpm)



Vturn-S20/60

Tailstock MT-4

- Twin cylinder clamping
- Tow along by turret
- Opt. MT-3 with built-in bearings



Vturn-S20/40

Rear / Right Chip Disposal

- Rectangular structure facilitates rear chip disposal (Vturn-S20/40 only) for less floor space (machine width 2300 mm)
- Gantry robot can be mounted on machine base for high reliability and productivity

Smooth & Steady Performance

Vturn-S26 Turning center

- One piece 30° slant bed
- Large swing diameter 600 mm
- 10" Power chuck / 3500 rpm
- Z-axis travel 610 / 1100 mm (S26/60, S26/110)
- High thrust force 1582 kgf
- High rapid feed 18/24 m/min (X/Z)
- C-axis available

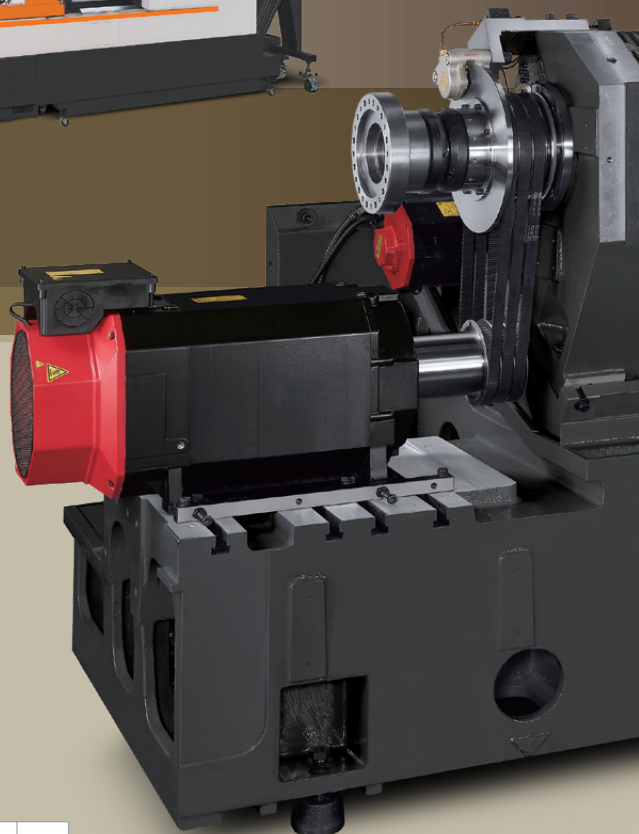

Spindle 22 kW (S3-25%)

- Spindle output 574 Nm (S3-25%)
- Low base speed 307 rpm only
- NN type (roller type) bearings
- Shortened belt length
- Victor Taichung's own spindle

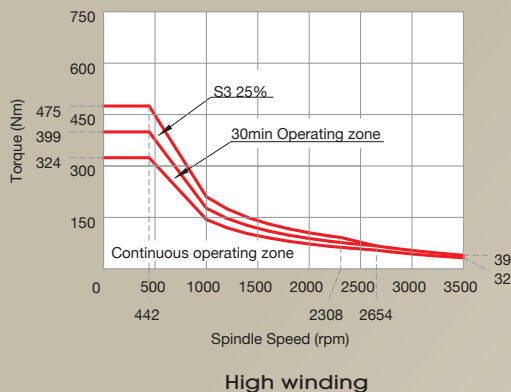
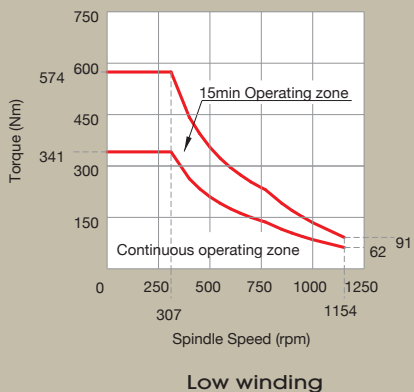
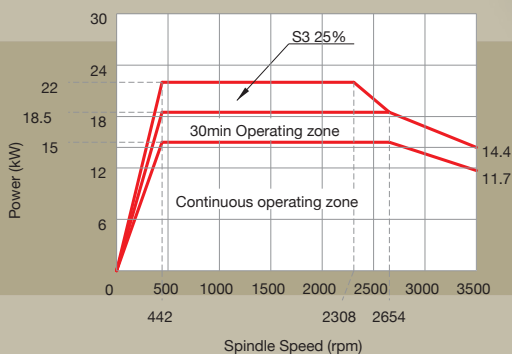
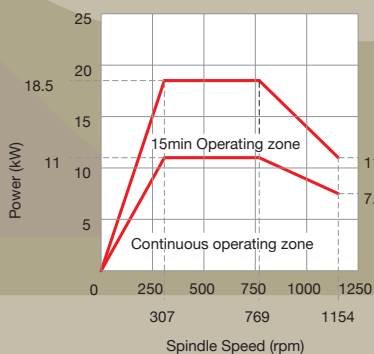

Fanuc motor αiIP30

Conventional design
with much longer belts

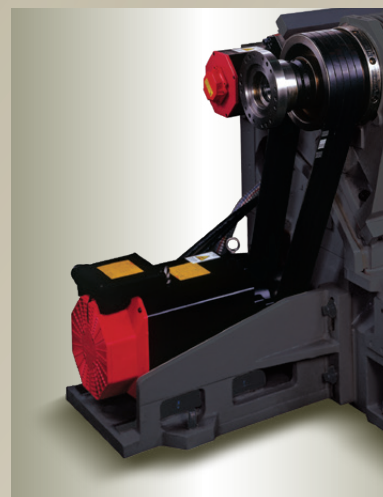

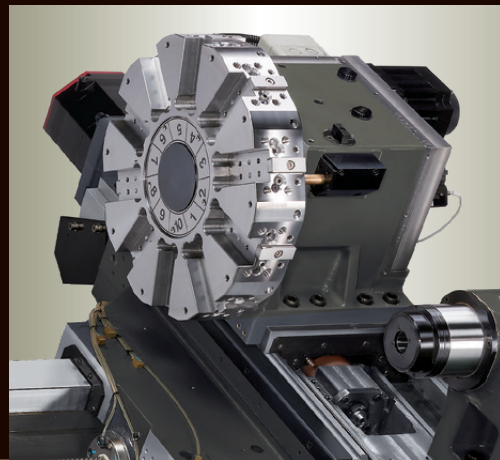
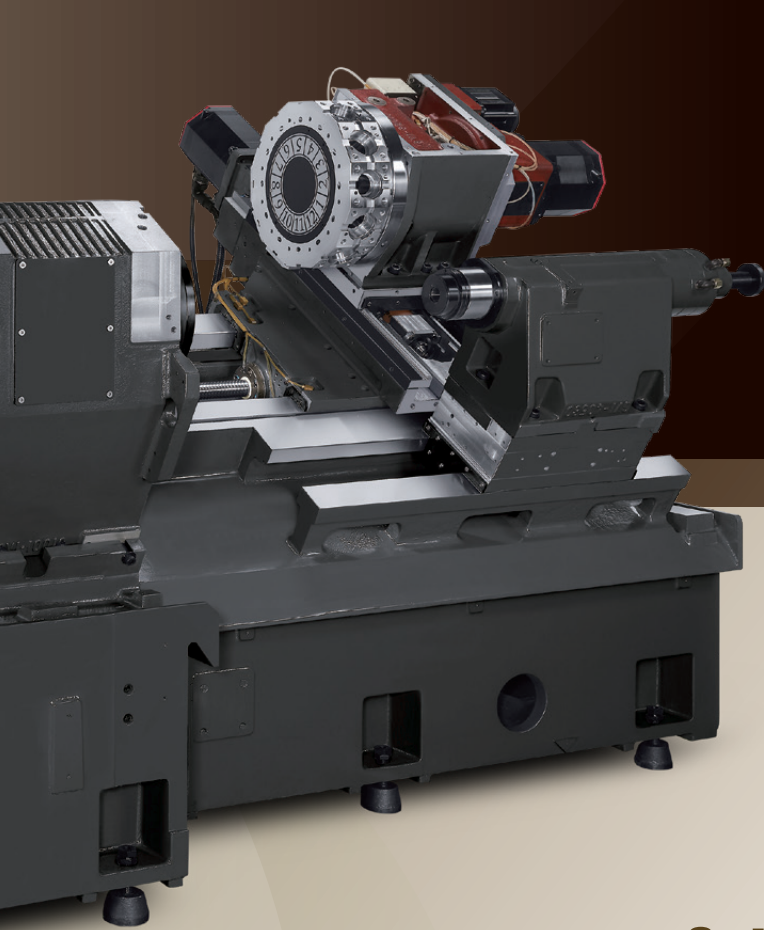

Victor's Own Turret 0.8 sec. (adjacent tools)

- Turret indexing time 0.8 sec (adj.), 1.0 (opposite)
- High thrust (Z-axis) 1441 kgf (14.1 kN)
- Opt. milling turret BMT-65 (3 piece coupling, servo)
- 12 station live tools
- Milling power 4.5 kW / 4000 rpm (opt. 6000 rpm)



Certificated Casting
GB300

Tailstock MT-5

- Twin cylinder clamping
- Tow along by turret
- Opt. MT-4 with built-in bearings

Boxways 64/80 mm (X/Z)

- High rapid feeds 18/24 m/min
- Smooth operation guaranteed
- Victor Taichung's own casting

Opt. Spindle 26 kW (S3-25%)

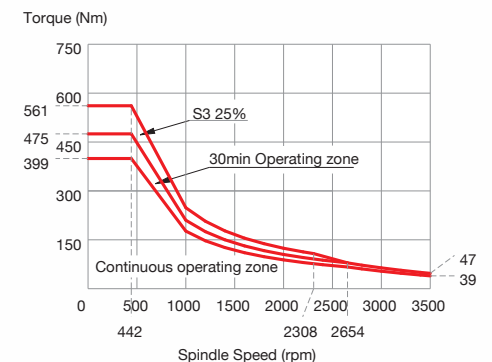
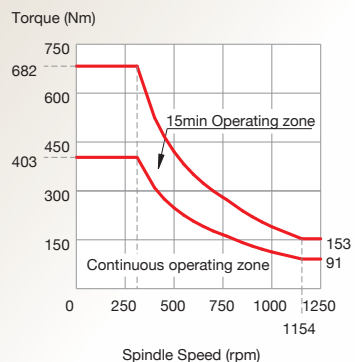
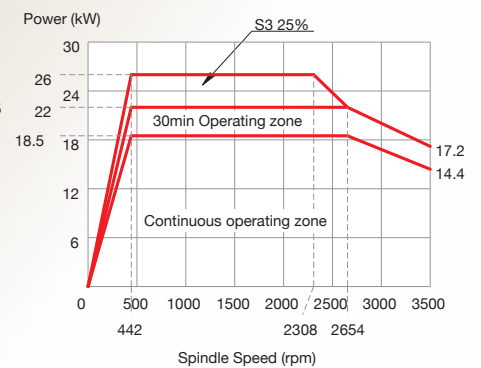
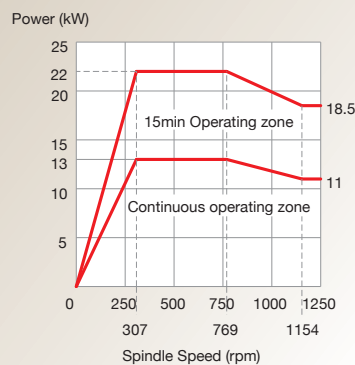

Low winding

High winding

Fanuc motor α IP40

Strong Performance by 2-step Gear

Vturn-S36 Turning center

- A2-11 spindle with 2-step gearbox
- One piece 45° slant bed
- Large swing diameter 780 mm
- 12" Power chuck / 2500 rpm
- Z-axis travel 850 / 1250 mm (S36/85, S36/125)
- High thrust force 1582 kgf
- High rapid feed 18/20 m/min (X/Z)
- C-axis available with higher power spindle motor

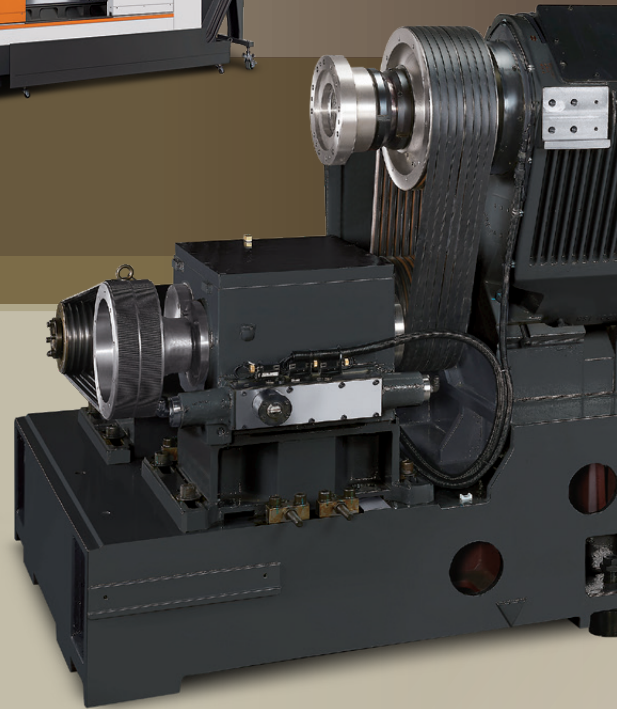

2-step gearbox

Spindle 35 kW (S3-25%)

- Spindle nose A2-11 with 2-step gearbox
- Spindle output 1201 Nm (S3-25%)
- Low base speed 278 rpm only
- NN type (roller type) bearings

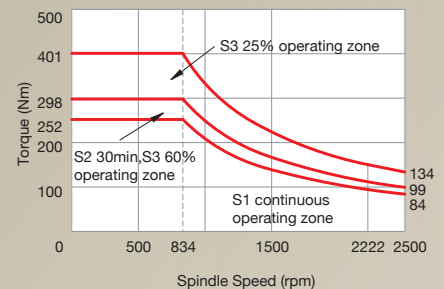
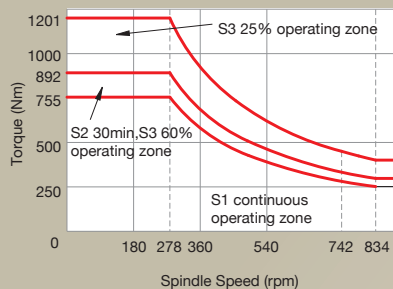
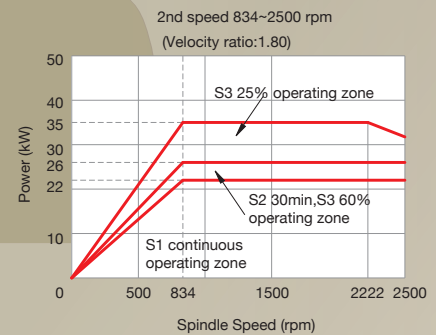
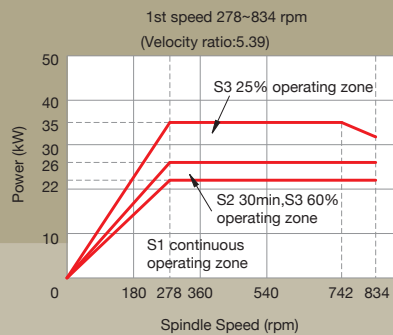

Low Speed

High Speed

Fanuc motor αiL22

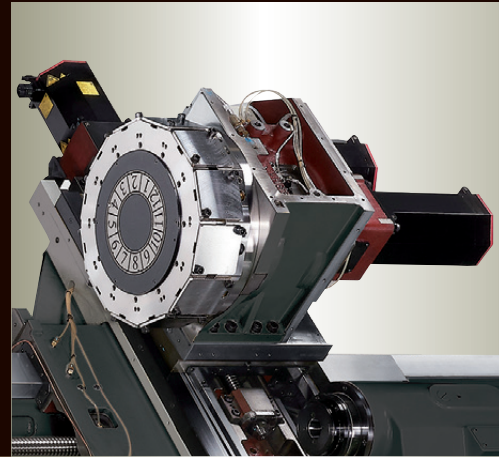
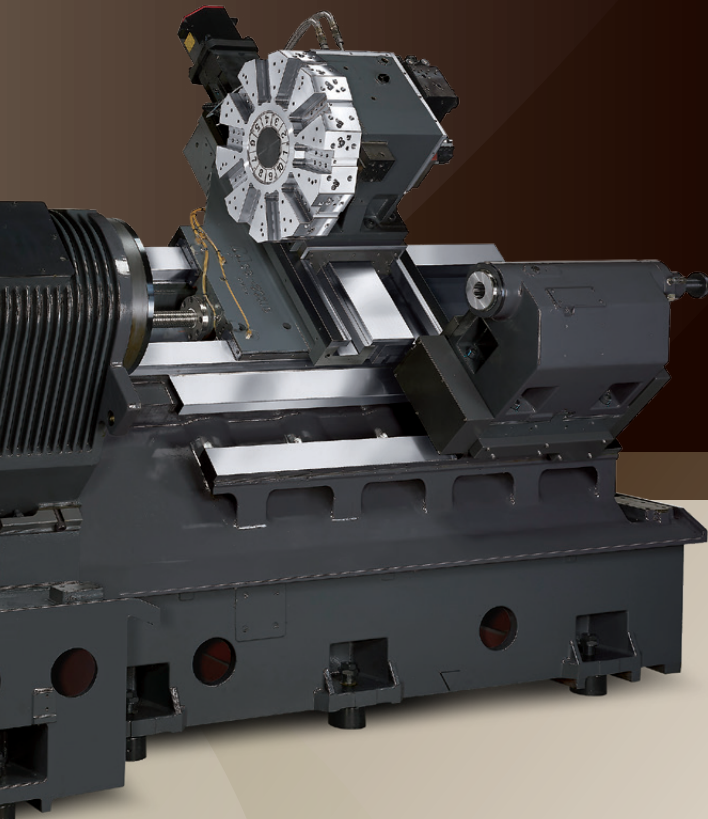

Victor's Own Turret

- Turret indexing time 0.9 sec. (adj.), 1.8 sec. (opposite)
- High thrust (Z-axis) 1582 kgf (15.5 kN)
- Opt. milling turret BMT-75 (3-piece coupling)
- 12 station live tools
- Milling power 7 kW / 3000 rpm

Boxways 85/90 mm (X/Z)

- High rapid feeds 18/20 m/min
- Smooth operation guaranteed

Tailstock MT-5

- Twin cylinder clamping
- Tow along by turret
- Opt. MT-4 with built-in bearings

Cs-axis (opt.) with GTP[®] gearbox and upgraded spindle motor 45 kW (S3-25%)

- GTP[®] 2-step gearbox
- Spindle output 2010 Nm (S3-25%)
- Low base speed 214 rpm only

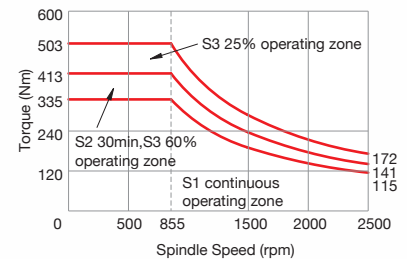
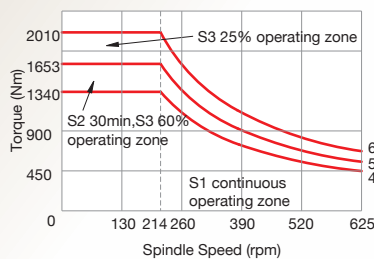
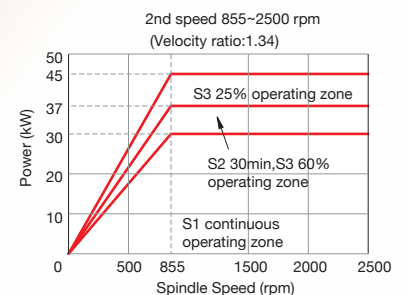
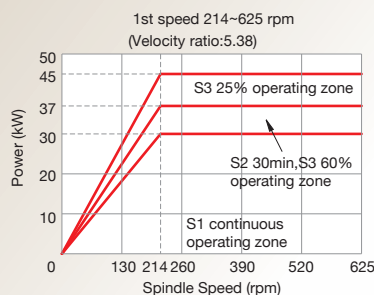
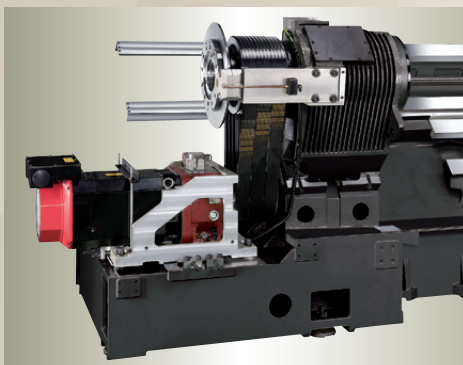

Low Speed

High Speed

Fanuc motor α 130

Standard and Options

- Fanuc Oi-TF Plus (type-1) control with 10.4" screen
- Programmable tailstock
- Rotary operation panel
- Door moving along LM guideways
- Coolant flush onto Z-axis covers
- Built-in LED light
- Pressure gauge in front
- Chip conveyor



Conveyor motor cover (opt.)



Chip conveyor (std.)

Coolant flush (std.)



Tooling accessories (excl. BMT turret model)

TOOLS \ MODEL	Vturn-S20	Vturn-S26	Vturn-S36
Tool shank for turret disk	25 mm (1")	25 mm (1")	32 mm (1 1/4")
Maximum boring bar dia.	40 mm (1 1/2")	50 mm (2")	50 mm (2")
Face + OD cutting tool holder	1	1	1
Face + ID. cutting tool holder	1	1	1
Boring bar holder			
40 mm (1 1/2")	6	7	-
50 mm (2")	Opt.	1	5
Boring bar sleeve			
8 mm (5/16")	1	1	-
10 mm (3/8")	2	2	1
12 mm (1/2")	2	2	1
16mm (5/8")	2	2	2
20 mm (3/4")	2	2	2
25 mm (1")	2	2	2
32 mm (1 1/4")	2	2	2
40 mm (1 1/2")	-	-	2
Drill socket			
MT1	1	Opt.	-
MT2	1	1	-
MT3	1	1	Opt.
MT4	Opt.	1	1
U drill socket			
20 mm	Opt.	Opt.	-
25 mm (1")	1	1	1
32 mm (1 1/4")	1	1	1
40 mm (1 1/2")	-	-	Opt.

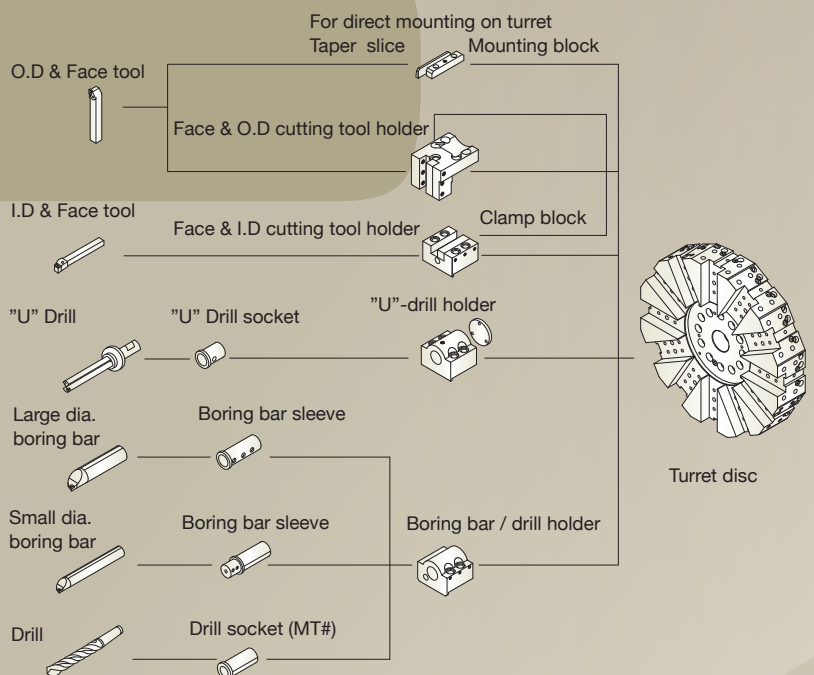



Transformer, A/C for cabinet (opt.)



15" screen (opt.)

Tool presetter (opt.)

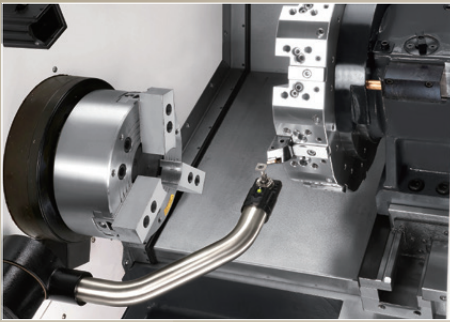

Gantry robot (opt.)



Recessed guarding for long tools (opt.)

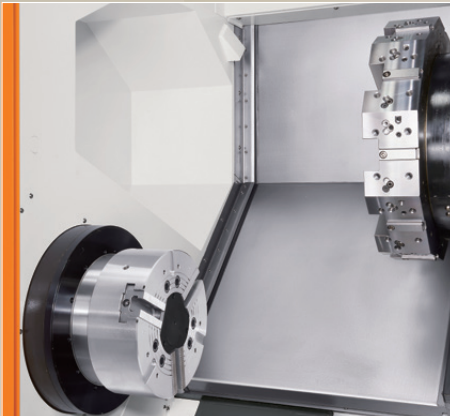

Part catcher (opt.)



*Vturn-S26

Oil skimmer (opt.)



Machine Color Option



 Standard



RAL-7024

C-axis Application

(Bolt Mounted Milling Turret)

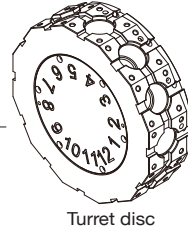
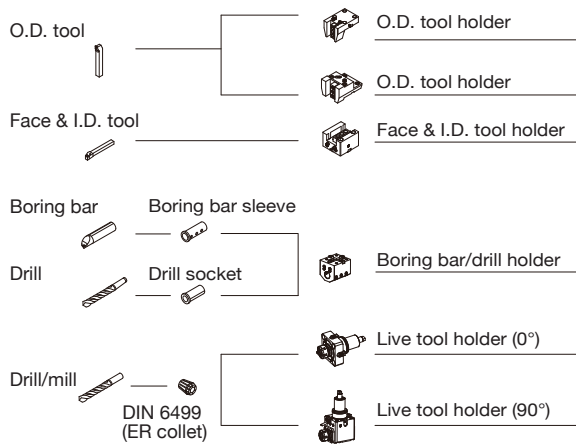

BMT-65 (Vturn-S26CM)

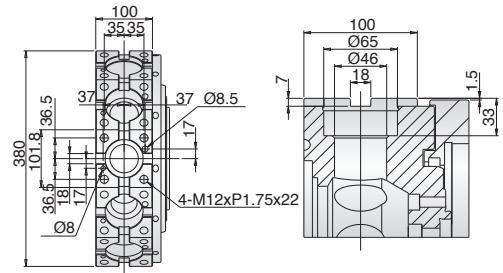

BMT-55 (Vturn-S20CM)

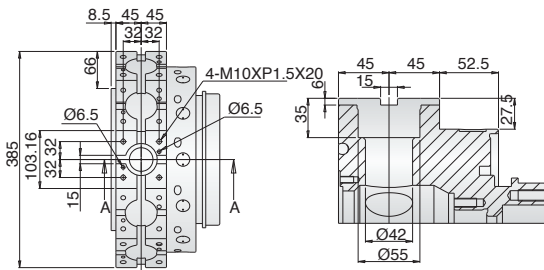

BMT-75 (Vturn-S36CM)

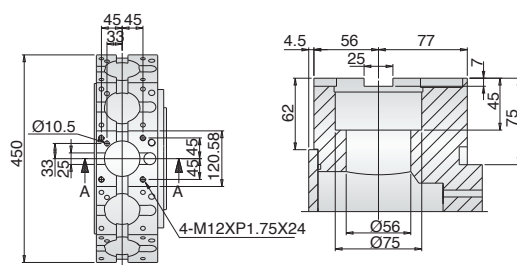

Unit: mm

Interference Chart/Operating Range

Vturn-S20

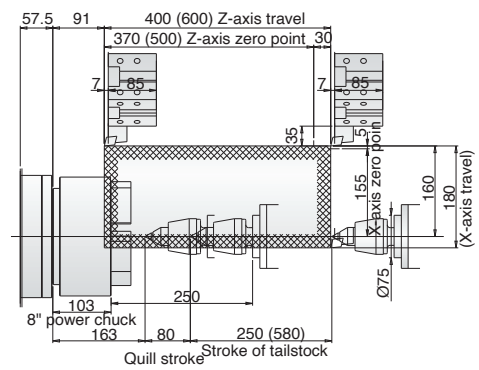
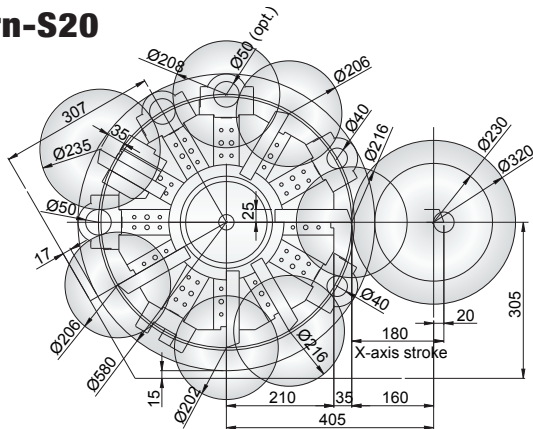

Vturn-S20CM

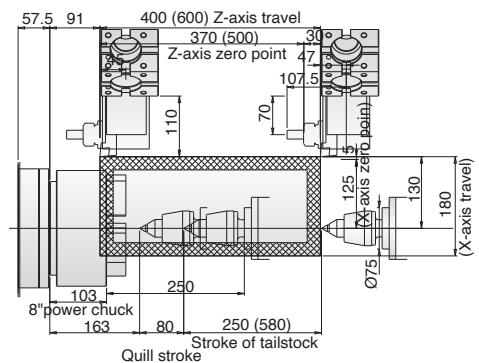
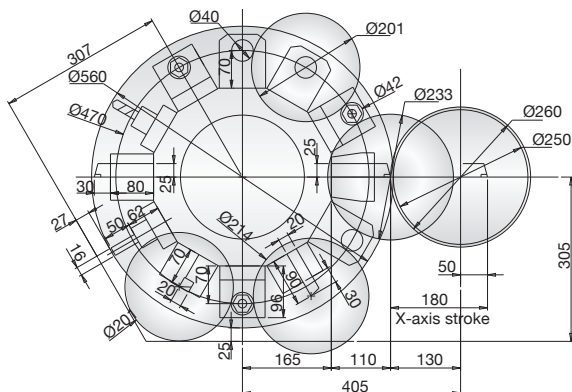

Vturn-S20/40 (S20/60)



Vturn-S26

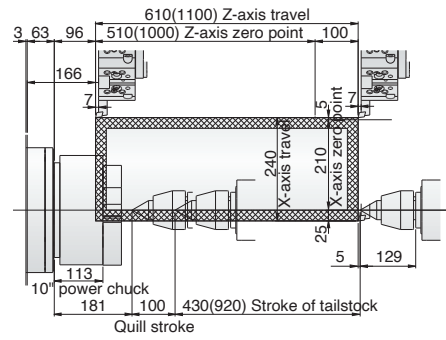
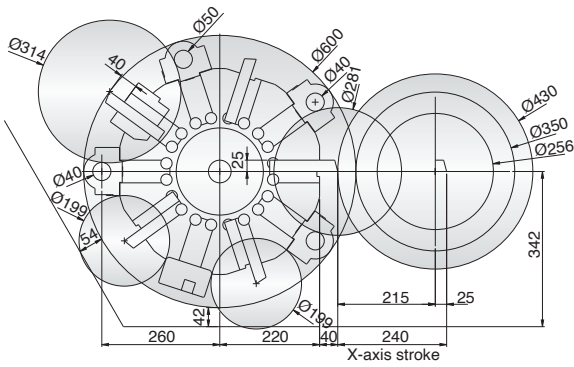

Vturn-S26CM

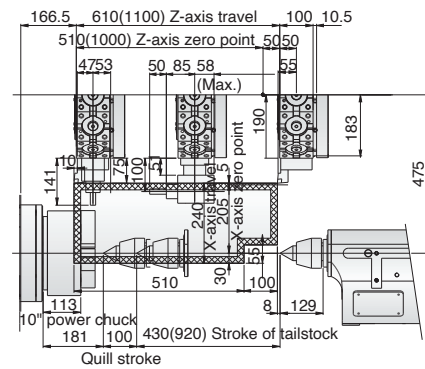
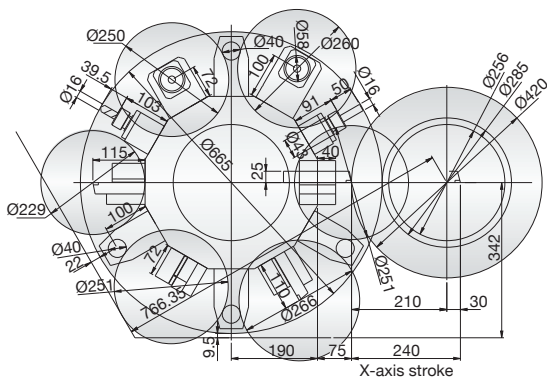

Vturn-S36

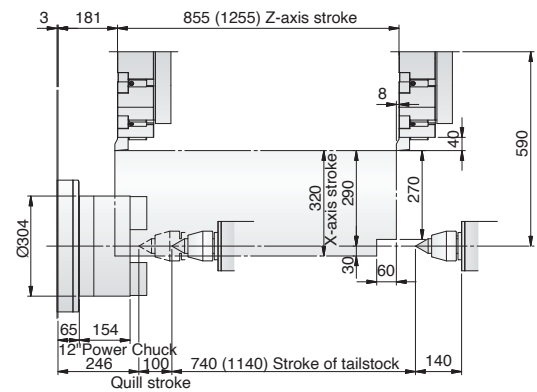
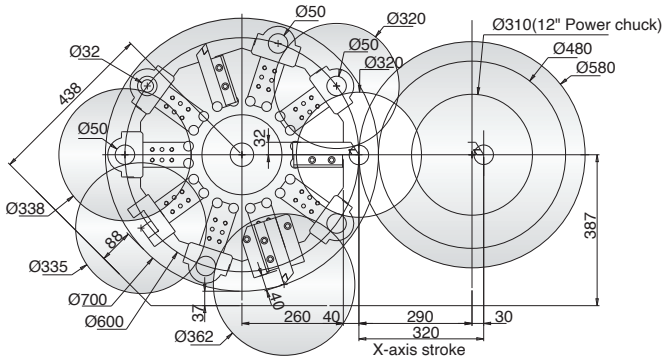

Vturn-S26/60 (S26/110)

Vturn-S36CM

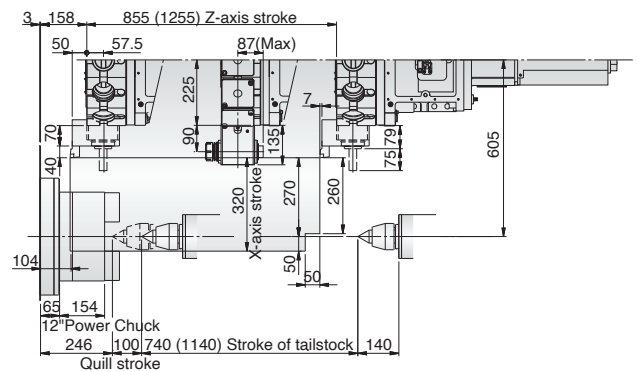
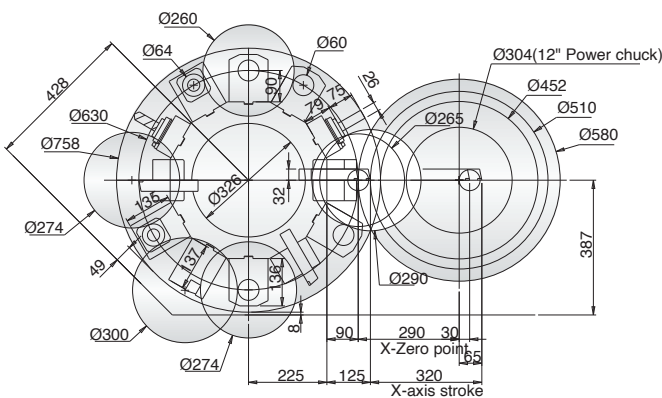

Vturn-S36/85 (S36/125)

Machine Layout

Vturn-S20/40 (std. rear disposal chip conveyor)

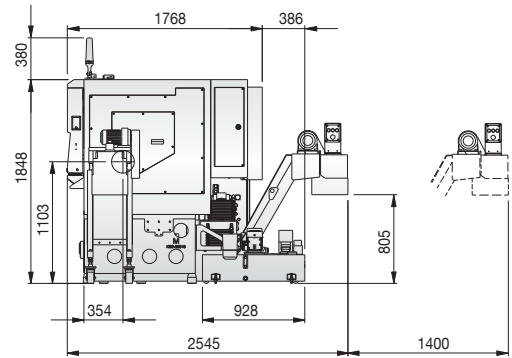
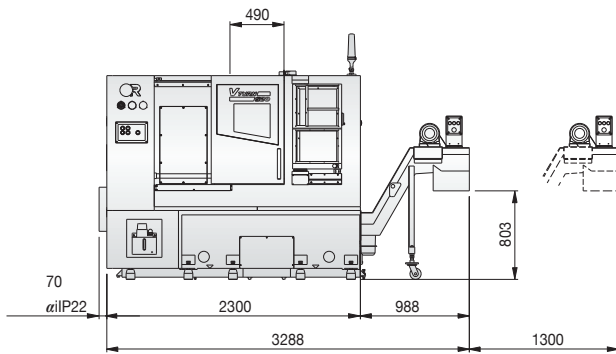
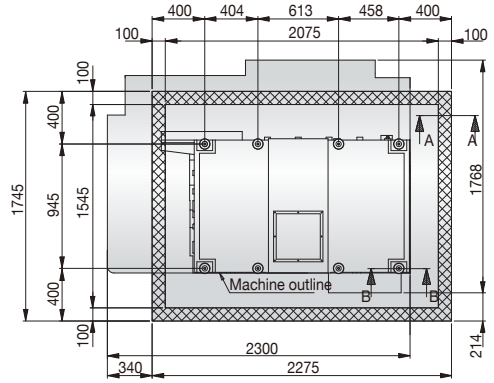
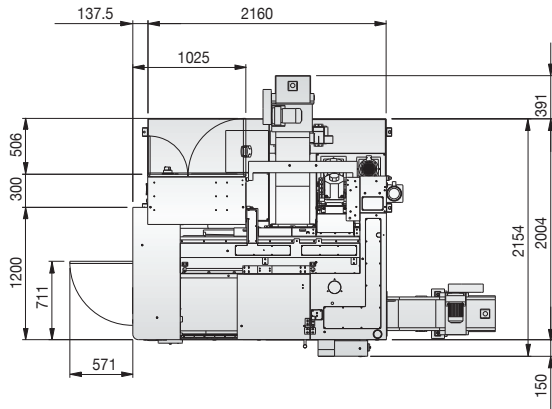

Unit: mm

Vturn-S20/60

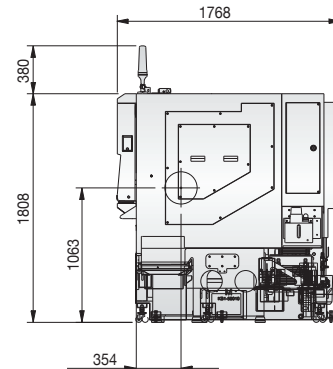
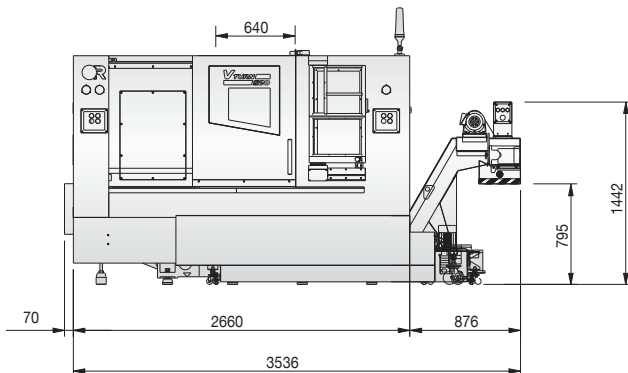
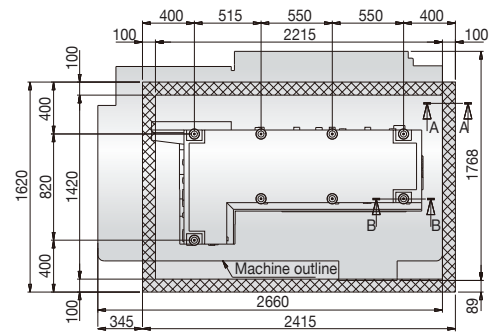
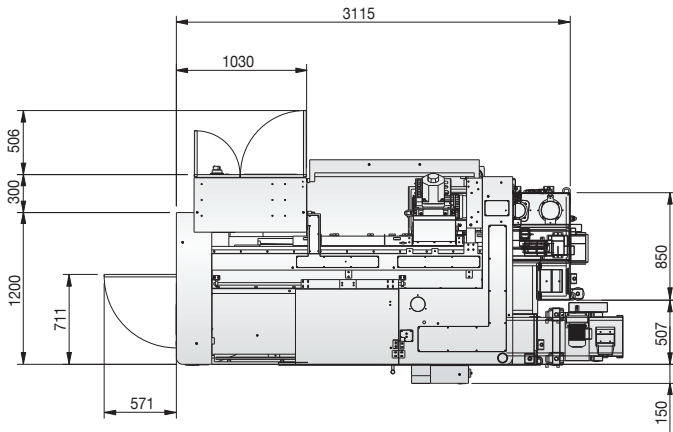

Unit: mm

Machine Layout

Vturn-S26/60

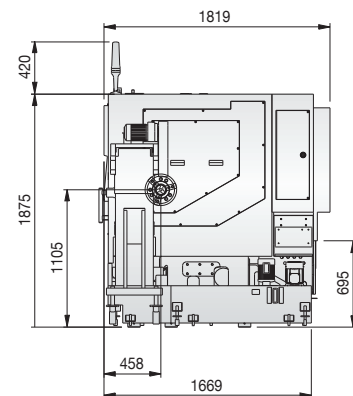
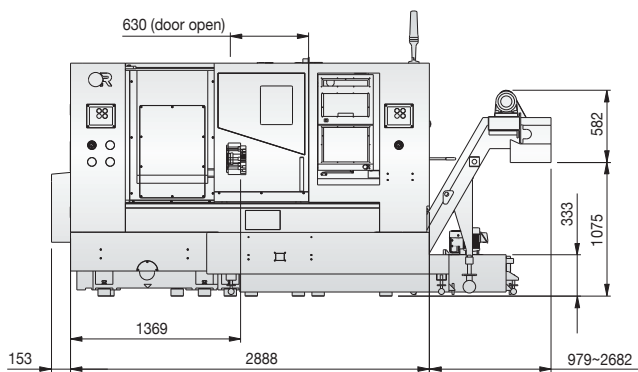
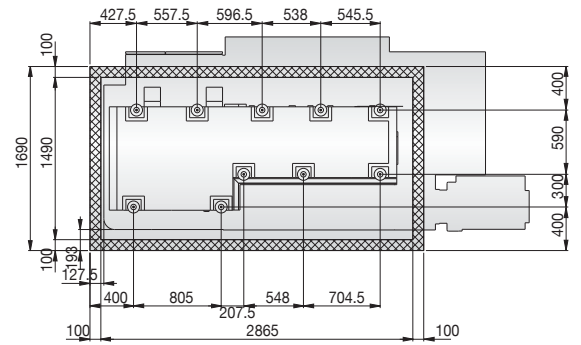
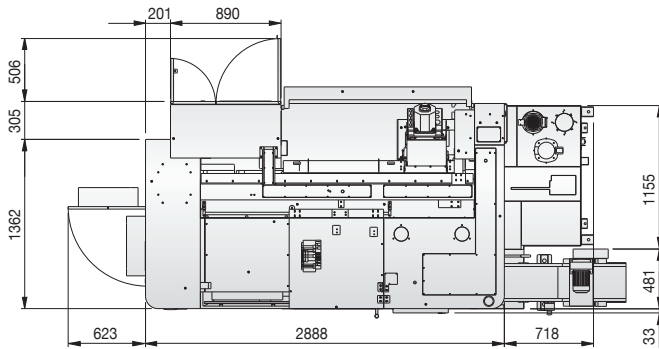

Unit: mm

Vturn-S26/110

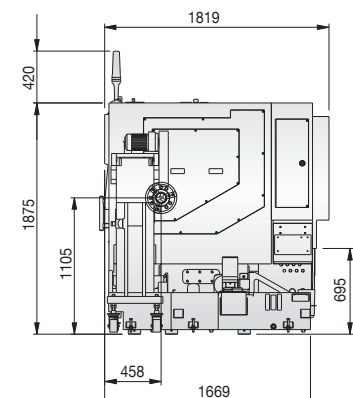
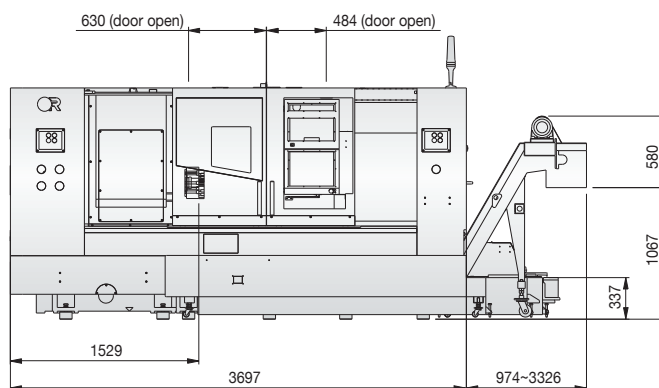
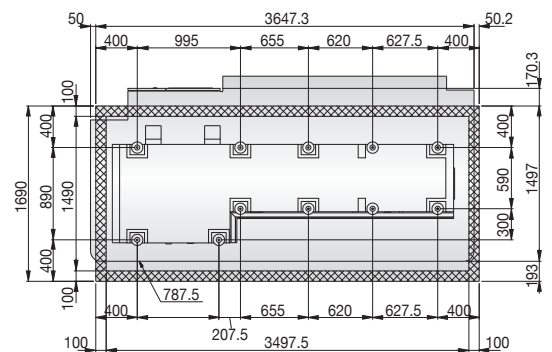
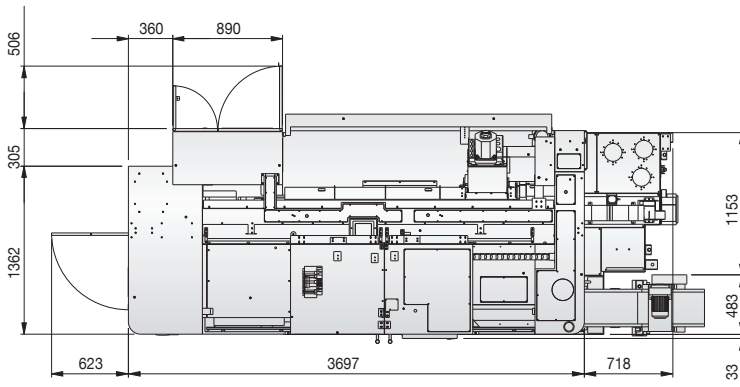

Unit: mm

Machine Layout

Vturn-S36/85

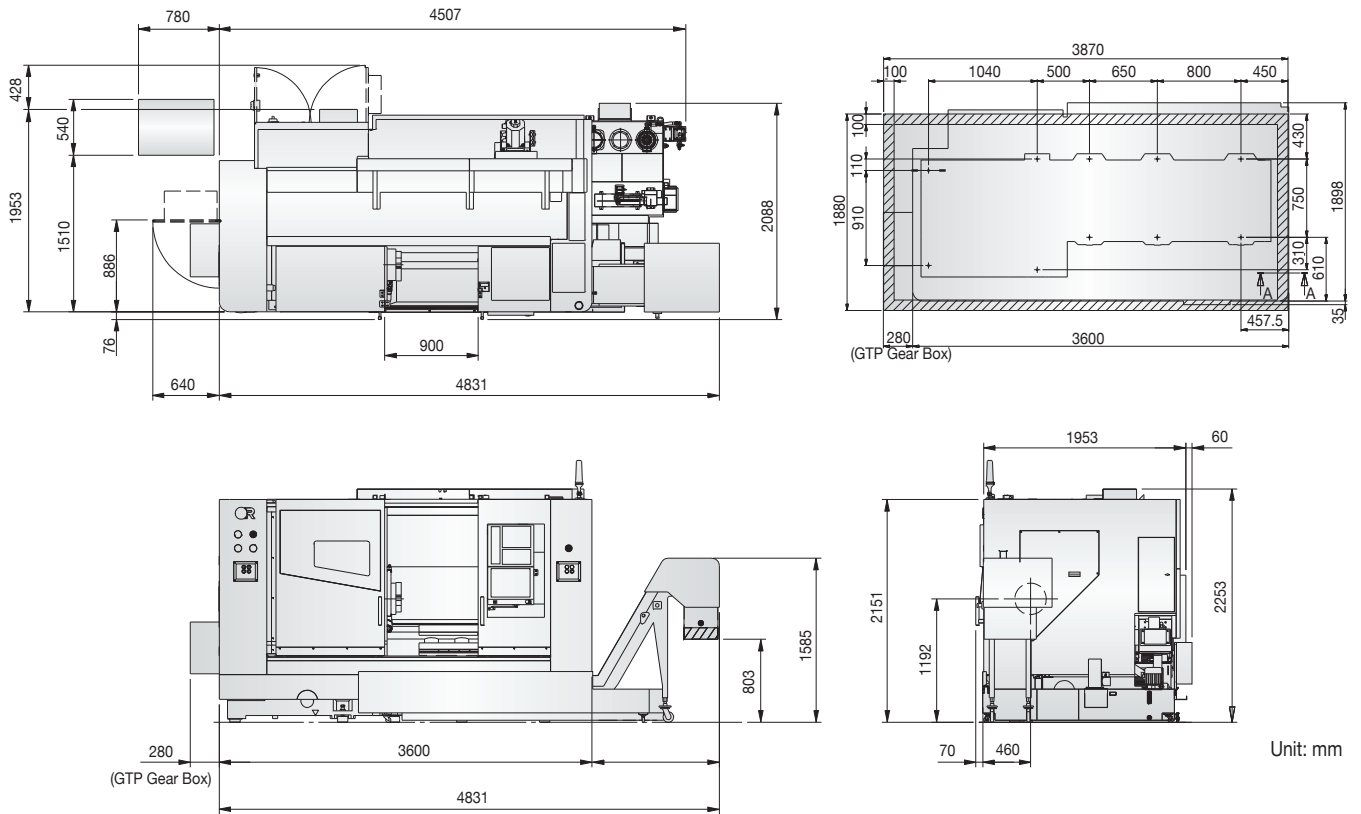

Vturn-S36/125

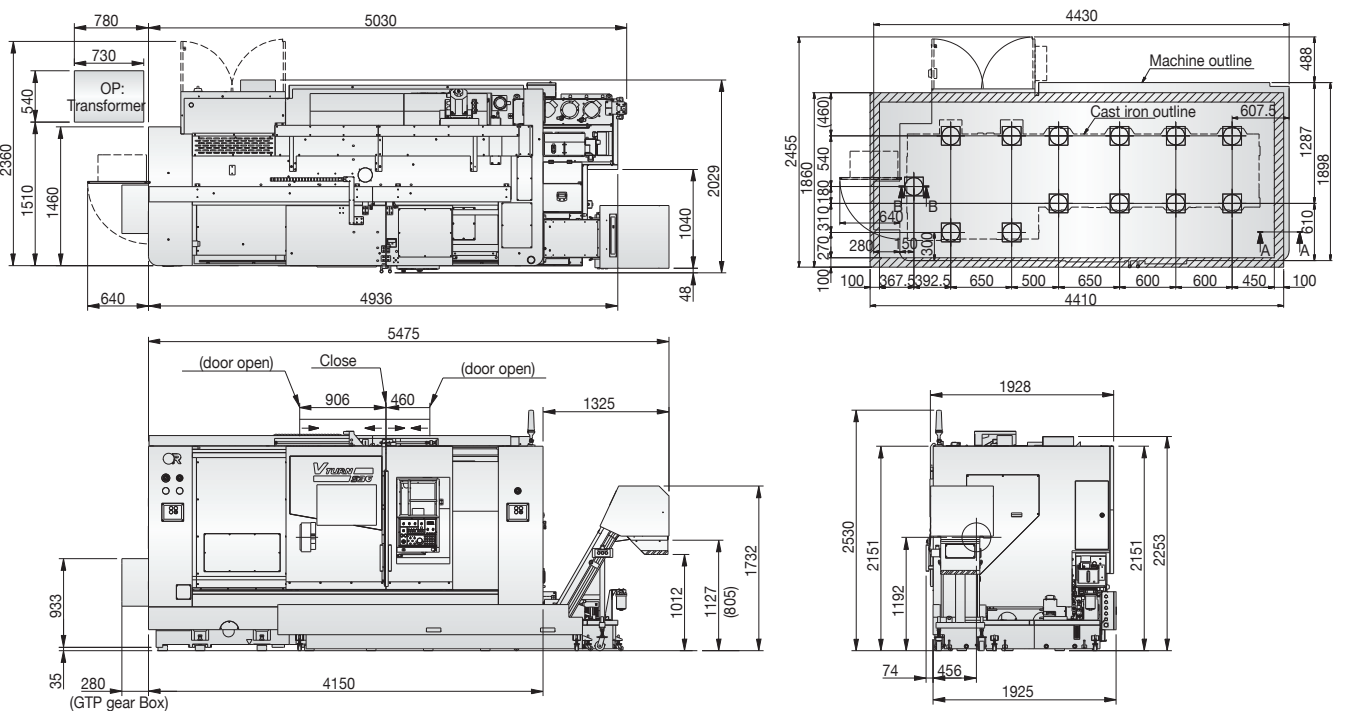

Machine Specification

Item \ Model		Unit	Vturn-S20/40 (CM) Vturn-S20/60 (CM)	Vturn-S26/60 (CM) Vturn-S26/110 (CM)	Vturn-S36/85 (CM) Vturn-S36/125 (CM)
CAPACITY	Swing over bed dia.	mm	Ø600	Ø600	Ø740 (limited by door)
	Standard turning dia.	mm	Ø230 (Ø250)	Ø350 (Ø285)	Ø480 (Ø452)
	Maximum turning dia.	mm	Ø320 (Ø260)	Ø430 (Ø420)	Ø580 (Ø580)
	Swing over carriage dia.	mm	Ø430	Ø480	Ø600
	Between centers	mm	420 640	640 1130	898 1298
	Bar capacity (Hole dia. thru draw bar)	mm	Ø52 (opt. 66)	Ø75 (opt. 77, 91)	Ø91 (opt. 117.5)
AXIS FEEDS	X axis travel	mm	160+20 (130+50)	215+25 (210+30)	290+30 (270+50)
	Z axis travel	mm	400 600	610 1100	855 1255
	Rapid feed - X / Z axis	m/min	20 / 24	18 / 24	18 / 20
	Feed motor - X / Z axis	kW	3 / 3	3 / 4	3 / 4 (4 / 4)
	JOG feed	mm/min	X/Z: 0~1260	X/Z: 0~1260	X/Z: 0~1260
	Ball screw dia. x pitch	mm	Ø32 x P6 (X), Ø40 x P8 (Z)	Ø32 x P6 (X), Ø40 x P8 (Z)	Ø36 x P6 (X), Ø50 x P8 (Z)
SPINDLE	Spindle speed	rpm	4200 (opt. 3500)	3500 (opt. 2500)	2500 (opt. 2000)
	Spindle nose (chuck)	inch	A2-6 (8")	A2-8 (10")	A2-11 (12")
	Spindle motor power (cont./30min/25%)	kW	7.5 / 9 / 12 (opt. 11 / 15 / 18.5)	15 / 18.5 / 22 (opt. 18.5 / 22 / 26)	22 / 26 / 35 (30 / 37 / 45)
	Spindle bearing inside dia.	mm	Ø100	Ø130	Ø160
	Spindle bore	mm	62 (opt. 78)	87	105 (opt. 135)
	Spindle taper		1/20	1/20	1/20
TURRET	No. of tools (live)		12 (12) servo	10 (12) servo	10 (12 servo)
	Tool shank size	mm	□25	□25	□32
	Max. boring bar dia.	mm	Ø40 (BMT-55)	Ø50 (BMT-65)	Ø50 (BMT-75)
	Exchange time (T-T)	sec	0.8 (0.81) - adjacent 1.0 (1.25) - opposite	0.8 (0.81) - adjacent 1.0 (1.25) - opposite	0.9 (1.36) - adjacent 1.78 (1.8) - opposite
	Milling speed	rpm	4000 (opt. 6000)	4000 (opt. 6000)	3000
	Milling motor	kW	2.2 (α iS 8/6000)	4.5 (α iS 22/6000)	7 (α iF 30/4000)
TAILSTOCK	Tailstock quill dia.	mm	Ø75	Ø110	Ø110
	Quill stroke	mm	80	100	100
	Quill taper		MT #4	MT #5 (opt. MT #4)	MT #5 (opt. MT #4)
ACCURACY	Positioning accuracy (bi-directional)	mm	0.01	0.01	0.01
	Repeatability	mm	±0.004	±0.004	0.01
MACHINE	NC controller	Fanuc	Oi-TF Plus (10.4")	Oi-TF Plus (10.4")	Oi-TF Plus (10.4")
	Coolant tank capacity	L	250 (overflow) 220	330 380	550 600
	Power requirement	kVA	17 (19)	27 (29)	38 (46)
	Machine dimension L x W x H (with chip conveyor)	mm	2300 x 2545 x 1848 (rear) 3536 x 1768 x 1808	4020 x 1819 x 1875 4671 x 1819 x 1875	4831 (5111) x 2029 x 2253 5475 (5755) x 2029 x 2253
	Net weight (incl. std. accessories)	kgs	4500 (4560) 4800 (4860)	6050 (6150) 6650 (6750)	9000 (9100) 9850 (9950)

* Machine and controller specifications are subject to change without notice.

** Available with CE / UKCA / TS / GB certificates.

Standard Accessories:

- Fanuc Oi-TF Plus (10.4") with Manual Guide i
- Hydraulic chuck with soft jaws
- Programmable tailstock
- Chip conveyor (rear disposal for VT-S20/40)
- Fully enclosed splash guarding
- Hand wheel
- Tool holders (for standard turret only)
- Coolant flush on Z-axis cover
- 3 step warning light

Optional Accessories:

- Manual tool presetter
- Auto tool presetter
- Parts catcher (N.A. for VT-S36)
- KITAGAWA® power chuck
- Air conditioner for electrical cabinet (Panel cooler)
- Higher pressure coolants
- Bar feeder interface
- Air blow
- Oil skimmer
- Oil mist collector
- Auto door
- Hard jaws
- Tailstock center
- Transformer
- C-axis
- Bar stopper

VICTOR Taichung's FANUC Oi-TF Plus 10.4" Control (Type I) Specifications

Standard

ITEM/SPECIFICATION	DESCRIPTION
Controlled Axes:	
1. Controlled axes	2 Axes (X, Z)
2. Simultaneous controlled axes	2 Axes
3. Least input increment	0.001mm
4. Least command increment	0.0005mm (X) / 0.001mm (Z)
5. Command system	Incremental / Absolute
6. HRV Control	HRV3+
7. Unexpected disturbance torque detection (AIR-BAG)	Std.
8. Backlash compensation	Std.
9. Stored pitch error compensation	Std.
Operation & Program Input:	
1. Input / Output interface	RS-232, PCMCIA Card, USB
2. Tool offset	99 sets
3. Sequence number	N5-Digit
4. Program number	O8-Digit
5. Program name	31-characters
6. M code function	M3-digit
7. S code function	S4-digit
8. T code function	T4-digit
9. Positioning	G00
10. Linear interpolation	G01
11. Circular interpolation	G02, G03
12. Programmable data input	G10
13. Plane selection	G17-G19
14. Inch / Metric conversion	G20 / G21
15. Reference position return	G28, G30
16. Thread cutting	G32, G34
17. Threading retract	Std.
18. Tool nose radius compensation	G40-G42
19. Work piece coordinate system	G52-G59
20. Macro, Sub program call	G65, M98, M99 (10 folds nested)
21. Multiple repetitive cycle I & II	G70-G76
22. Canned cycle for drilling	G80-G89
23. Canned cycles	G90, G92, G94
24. Program stop / end	M00-M02 / M30
25. Rigid tapping (Spindle)	M29
26. Manual Guide i	Std.
27. Optional blocks skip 2-9	Std.

Feed Function:

1. Manual handle feed rate	X1, X10, X100
2. Rapid traverse rate	F0, 25%, 50%, 100%
3. Cutting feed rate	0-150%
4. Spindle override	50-120%
5. Feed per Minute / Revolution	G98 / G99

Edit Operation:

1. Part Program Storage Length (in total)	5120m (2MB)
2. Number of Registerable programs (in total)	1000
3. Part Program Editing	Std.
4. Memory card program entry count extension (Max. 1000)	Std.

C Axis Function:

1. Polar coordinate interpolation	Std. (G112/G113)
2. Cylindrical interpolation	Std. (G107)
3. CS contouring control	Std.
4. Coordinate System Rotation	Std.

Options

With hardware included

1. Tool life management	<input type="checkbox"/>
2. Program restart	<input type="checkbox"/>
3. Data server (with PCB and CF card 1GB)	<input type="checkbox"/>
4. Ethernet/IP (to be linked to robot)	<input type="checkbox"/>
5. PROFIBUS-DP (to be linked to robot)	<input type="checkbox"/>
6. CC-Link (to be linked to robot)	<input type="checkbox"/>
7. Fast Ethernet (required for SCADA Web with additional RJ45 port)	<input type="checkbox"/>

Without hardware included

8. Circular thread cutting (G35, G36)	<input type="checkbox"/>
9. AICC-1 (G5.1 Q1, 40 blocks)	<input type="checkbox"/>
10. AICC-2 (G5.1 Q1, 200 blocks)	<input type="checkbox"/>
11. Helical interpolation (C-axis only)	<input type="checkbox"/>
12. Arbitrary speed threading	<input type="checkbox"/>

Milling Motor Output

Vturn-S20CM

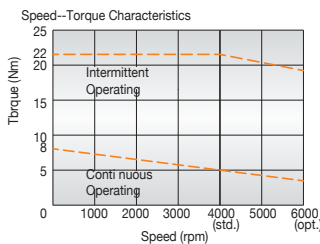

αiS 8/6000 (2.2 kW)

Vturn-S26CM

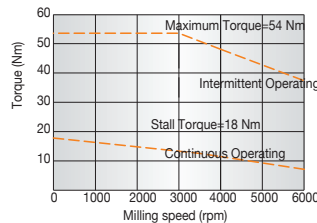

αiS 22/6000 (4.5 kW)

Vturn-S36CM

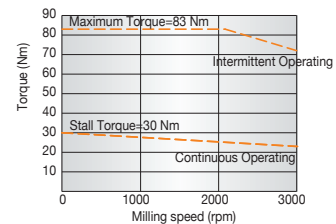

αiF 30/4000 (7 kW)



THE VICTOR-TAICHUNG COMPANIES

TAIWAN

http://www.victortaichung.com
E-mail : info@mail.or.com.tw
Victor Taichung Machinery Works Co., Ltd.
No. 1, Jingke Central 2nd Rd.,
Nantun Dist., Taichung 40852,
TAIWAN, R.O.C.
TEL : 886-4-23592101
FAX : 886-4-23593389

FRANCE

Victor France
TEL : 33-1-64772000
FAX : 33-1-64772063

GERMANY

Victor GmbH
TEL : 49-2261-478434
FAX : 49-2261-478327

SOUTH AFRICA

Victor Fortune (PTY) Ltd.
TEL : 27-11-3923800
FAX : 27-11-3923899

MALAYSIA

Victor Machinery (M) SDN. BHD.
TEL : 60-3-56337180
FAX : 60-3-56337191

THAILAND

Victor CNC (Thailand) Co., Ltd.
TEL : 66-2-9263735
FAX : 66-2-9032373

INDONESIA

PT. Victor Machinery Indonesia
TEL : +62-21-88958504
FAX : +62-21-88958513

USA

Fortune International Inc.
TEL : 1-732-2140700
FAX : 1-732-2140701

CHINA

Victor Taichung
Machinery (Shanghai)
TEL : 86-21-59768018
FAX : 86-21-59768009



HTL



VTL



VMC



HMC



XMT



PIM



was also marketed under the brand names VICTOR (outside North America) and FORTUNE GV1GE23EE